

Security System

User's Manual

VISTA
4120XM
4140XMP

ADEMCO

N6491V2 1/94

TABLE OF CONTENTS

| | |
|--|----|
| SYSTEM OVERVIEW | 4 |
| Consoles | 4 |
| Zones | 4 |
| Fire Protection | 5 |
| Burglary Protection | 5 |
| Alarms | 5 |
| ABOUT THE CONSOLES | 6 |
| The Alpha Console (all styles) | 6 |
| The Fixed-Word Console (all styles) | 7 |
| SUMMARY OF CONSOLE FUNCTIONS | 8 |
| ENTRY/EXIT DELAYS | 11 |
| SECURITY CODES | 12 |
| User Codes | 12 |
| Duress Code | 12 |
| Quick Arming | 13 |
| To Assign and Delete User Codes | 13 |
| CHECKING FOR OPEN ZONES | 14 |
| BYPASSING PROTECTION ZONES | 16 |
| Quick Bypass Feature | 16 |
| Displaying Bypassed Protection Zones | 16 |
| ARMING PERIMETER ONLY (With Entry Delay On) | 18 |
| ARMING PERIMETER ONLY (With Entry Delay Off) | 20 |
| ARMING ALL PROTECTION (With Entry Delay On) | 22 |
| ARMING ALL PROTECTION (With Entry Delay Off) | 24 |
| DISARMING THE SYSTEM AND SILENCING ALARMS | 26 |
| CHIME MODE | 27 |
| DURESS CODE | 28 |
| PANIC (EMERGENCY) KEYS | 29 |

TABLE OF CONTENTS

| | |
|---|--------|
| USING THE KEYSWITCH | 30 |
| VIEWING CENTRAL STATION MESSAGES | 32 |
| SELF-HELP FEATURE | 33 |
| REVIEWING ALL ZONE DESCRIPTIONS | 33 |
| TESTING THE SYSTEM | 34 |
| TROUBLE CONDITIONS (Alpha Console) | 36 |
| TROUBLE CONDITIONS (Fixed-Word Console) | 38 |
| FIRE ALARM SYSTEM (If Installed) | 40 |
| In Case Of Fire Alarm | 40 |
| Silencing Fire Alarms | 41 |
| NATIONAL FIRE PROTECTION ASSN. RECOMMENDATIONS | 42 |
| EMERGENCY EVACUATION | 43 |
| SUMMARY OF AUDIBLE SOUNDS AND DISPLAYS (Alpha Console) | 44 |
| SUMMARY OF AUDIBLE SOUNDS AND DISPLAYS (Fixed-Word Console) | 45 |
| PROTECTION ZONES | 46 |
| QUICK REFERENCE OPERATING GUIDE | 48 |
| MAINTAINING YOUR SYSTEM | 49 |
| Replacing Batteries in Wireless Sensors | 49 |
| Silencing Low Battery Warning Tones at the Console | 50 |
| Routine Care | 50 |
| FCC STATEMENTS, PART 15 and PART 68 | 51, 52 |
| OWNER'S INSURANCE PREMIUM CREDIT REQUEST FORM | 53 |
| CANADIAN DEPARTMENT OF COMMUNICATIONS (DOC) STATEMENT | 55 |
| THE LIMITATIONS OF THIS ALARM SYSTEM | 56 |
| WARRANTY | 58 |
| IN THE EVENT OF TROUBLE WITH YOUR REGULAR TELEPHONE SERVICE | 59 |

SYSTEM OVERVIEW

General

Congratulations on your ownership of an Ademco Security System. You've made a wise decision in choosing it, for it represents the latest in security protection technology today, including microcomputer technology to monitor the system's status at all times. Ademco is the world's largest manufacturer of security systems and millions of premises are protected by Ademco systems.

Basically, this system offers you three forms of protection – burglary, fire and emergency. Your system consists of at least one console which provides full control of system operation, plus various devices such as door and window sensors and motion detectors. It may also include a selected number of smoke or combustion detectors designed to provide early warning in case of fire.

Consoles

Your consoles allow you to control all system functions, and feature a telephone style (digital) keypad, a Liquid Crystal Display (LCD) that shows the nature and location of all occurrences, and a built-in sounder which sounds during alarms and troubles. Your System can use either the Fixed-Word Display console or the Alpha Display console (see *ABOUT THE CONSOLES*).

Unless stated otherwise, all commands and procedures apply equally to both types of Consoles.

Protection zones

Your system's sensing devices have been assigned to various "protection zones". For example, the sensing device on your designated Entry/Exit door may have been assigned to zone 01, sensing devices on a window in the master bedroom to zone 02, and so on. These zone numbers will appear on the console display when an alarm or trouble condition occurs.

SYSTEM OVERVIEW

Fire Protection

The fire protection portion of your security system (if used) is always on, and sounds an alarm if a fire condition is detected. Refer to the *FIRE ALARM SYSTEM* section for important information concerning fire protection, smoke detectors and planning emergency exit routes.

Burglary Protection

The burglary protection portion of your system must be turned on or "armed" before it can sense burglary alarm conditions and sound an alarm. Your system can be armed in one of four modes: STAY, AWAY, INSTANT and MAXIMUM. Refer to the *ARMING* sections for instructions in using these modes of operation. The principal differences between these four arming modes will be seen in the chart below.

SUMMARY OF ARMING MODES

| Arming Mode | Features For Each Arming Mode | | | |
|-------------|-------------------------------|-------------|-----------------|----------------|
| | Exit Delay | Entry Delay | Perimeter Armed | Interior Armed |
| AWAY | Yes | Yes | Yes | Yes |
| STAY | Yes | Yes | Yes | No |
| INSTANT | Yes | No | Yes | No |
| MAXIMUM | Yes | No | Yes | Yes |

Alarms

When an alarm occurs, both the console and external sounders sound, and the console displays the protection zone(s) causing the alarm. If your system is connected to a central monitoring station, an alarm message is also sent. To stop the alarm sounding, simply disarm the system.

ABOUT THE CONSOLES

Console Types

There are two basic types of consoles – a FIXED-WORD console and an ALPHA console. Either (or both) of these console types may have been used in your particular system. Both types feature a multifunction, backlit 12-key digital keypad, and a Liquid Crystal Display (LCD). A built-in sounder emits alarm sounds during alarm conditions, and produces warning tones during entry and exit delay periods. This sounder also provides acknowledgment tones when keys are pressed, and confirmation tones for successful command entries.

Console Styles

Fixed-Word and Alpha consoles are available in two styles, A and B, either of which may have been used in your system. Although different in appearance, both styles are functionally similar. The keypads on Style "B" consoles are located behind a flip-down door which can be removed, if desired. Message displays on all Alpha consoles are identical; words displayed on all Fixed-Word consoles are the same, except that their location in the display window will differ slightly with each style. All available consoles are shown on the right.

The Style "B" Alpha console, with an appropriate message display, is depicted in the instructions throughout this manual; in each case, however, it is always accompanied by the equivalent message display on a Fixed-word console.

Unless noted otherwise, all procedures in this manual apply equally to all console types and styles.

The Alpha Console (All Styles)

Alpha consoles feature a 2-line, 32-character fully programmable alphanumeric Liquid Crystal Display (LCD) which can display the nature and location of all occurrences in friendly English. Abbreviated User's instructions can also be displayed on an Alpha console's display screen (see SELF-HELP FEATURE on page 33). This feature is useful if this Manual is not accessible when you need to perform a procedure with which you are not familiar.

SUMMARY OF CONSOLE FUNCTIONS

- 1. DISPLAY WINDOW:** The ALPHA Console features a 2-line, 32-character Liquid Crystal Display (LCD) that displays protection point identification, system status, and messages.
The FIXED-WORD Console provides the same basic information, but uses fixed word displays. See page 10 for Fixed-Word display messages and their meanings.
- 2. OFF KEY:** Used to disarm the burglary portion of the system, silence alarms and audible trouble tones, and clear visual displays after a problem has been corrected.
- 3. AWAY KEY:** Used to arm the entire burglary system, perimeter and interior.
- 4. STAY KEY:** Used to arm the perimeter portion of the burglary system only. Interior protection is not armed, which allows movement within your premises without causing an alarm. Entry delay feature is in effect.
- 5. MAX (MAXIMUM) KEY:** Used to arm in manner similar to AWAY mode, but without the entry delay feature, for maximum protection. An alarm will occur immediately upon opening any protection point, including a designated Entry/Exit door (or doors).
- 6. TEST KEY:** Tests the system and alarm sounder if disarmed. Refer to *TESTING THE SYSTEM* section.
- 7. BYPASS KEY:** Removes individual protection zones from being monitored by the system.
- 8. INSTANT KEY:** Arms in manner similar to STAY mode, but without the entry delay feature.
- 9. CODE KEY:** Used to assign additional user codes that can be given to other users of the system.
- 10. CHIME KEY:** Used to turn CHIME mode on and off. When on, the opening of protected windows and doors will produce 3 tones at the Console(s).
- 11. [*] READY KEY:** Used to display all open protection zones. This key is also used to display all protection zone descriptions that have been programmed for Alpha consoles in your system, by holding the key down for at least 5 seconds.
- 12. [#] KEY:** "Quick Arm" key permits ARMING of the system without the use of a security code (if programmed to do so).
- 13. KEYS 0-9:** Used to enter your security code(s).
- 14. READY INDICATOR: (GREEN)** Lit when system is ready for arming (no protection zones open). When the system is disarmed, this indicator will go on and off as protection zones are opened and closed.
Note: On some consoles, a **POWER** indicator is provided in place of a READY light which, when on, indicates that AC power is present, and when off, indicates that AC has been cut off and that the system is operating on the back-up battery.

15. **ARMED INDICATOR:** (RED) Lit when the system has been armed (STAY, AWAY, INSTANT or MAXIMUM).

16. **INTERNAL SOUNDER:** The built-in console sounder provides alarm sounds during alarms, and also emits tones during certain system functions. (see SUMMARY OF AUDIBLE SOUNDS AND DISPLAYS).

17. **EMERGENCY KEYS:**
Individual keys **A, B, and C** (key **D** not used).

On some consoles, these keys are not available, and the following key pairs are used for emergency functions:

- [*] & [#]
- [*] & [1]
- [#] & [3]

These keys may be programmed for panic functions by your installer (see PANIC section on page 29).

IMPORTANT!:
When entering codes and commands, sequential key depressions must be made within 3 seconds of one another. If 3 seconds elapses without a key depression, the entry is aborted and must be repeated from its beginning.

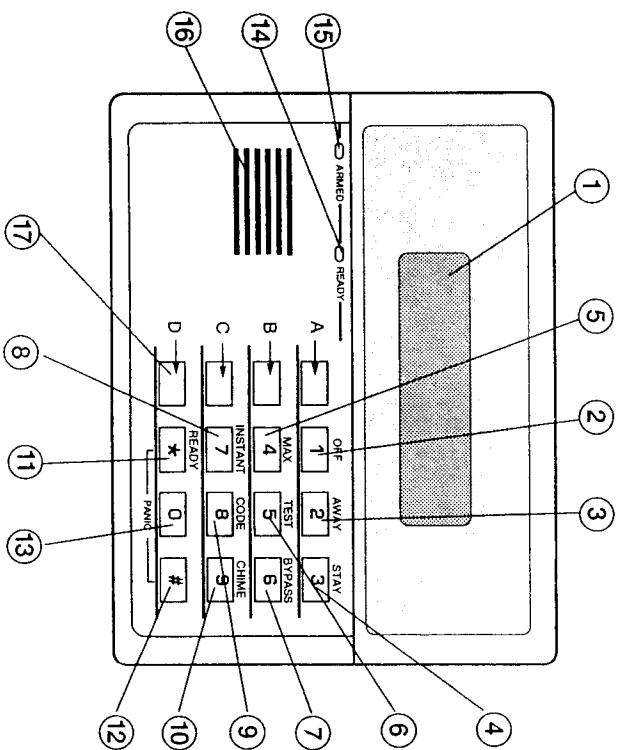

Typical Style "B" Alpha Console shown above. Fixed-Word Consoles are functionally the same except for screen displays and emergency key configuration.

FIXED-WORD CONSOLE – WINDOW DISPLAYS

| | |
|------------------|---|
| AWAY | All burglary protection zones, interior & perimeter, are armed. |
| STAY | Perimeter burglary protection zones, such as windows and doors, are armed. |
| INSTANT | Perimeter burglary protection zones armed and entry delay is turned off. |
| BYPASS | One or more burglary protection zones have been bypassed. |
| NOT READY | Appears when the burglary system is not ready for arming (due to open protection zones). |
| READY | The burglary portion of the system is ready to arm. |
| NO AC | Appears when AC power has been cut off. |
| AC | Appears when AC power is present. |
| CHIME | Appears when the CHIME feature is ON. |
| BAT | With no zone # present, indicates low system battery; with zone #, it indicates low wireless transmitter battery. |
| ALARM | Appears when an intrusion has been detected and the system is armed (also appears during a Fire or audible alarm). Accompanied by the ID # of zone in alarm. |
| CHECK | Appears whenever a malfunction is present, or whenever there is a fault in a FIRE zone, or in a 24-hour burglary zone during a disarmed period. Accompanied by a display of zone number in trouble. |
| FIRE | Appears when a fire alarm is present. Accompanied by a display of the zone # in alarm. |

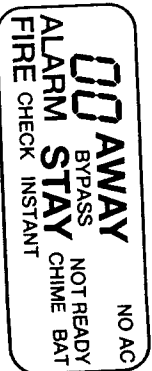
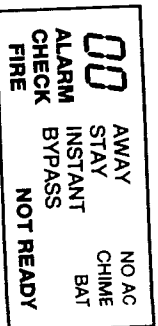

ENTRY/EXIT DELAYS

General Information

Your system has preset time delays, known as an exit delay and an entry delay. When you arm your system, the **Exit delay** gives you time to leave through a designated entry/exit door (or doors) without setting off an alarm. If programmed by your installer, a series of slow warning tones will be emitted by the console during the exit delay period.

The **Entry delay** gives you time to disarm the system when you re-enter through a designated entry/exit door, but the system must be disarmed before the entry delay period ends, or an alarm will occur. The console will emit tones during the entry delay period, reminding you to disarm the system. You can also arm the system with no entry delay at all by using either INSTANT or MAXIMUM arming modes. These modes can provide greater security when sleeping or while away for extended periods of time. See your installer for your delay times, which should be entered below.

DESIGNATED MAIN ENTRY/EXIT*

Location

Exit Delay 1: seconds

Entry Delay 1: seconds

DESIGNATED ALTERNATE ENTRY/EXIT*

Location

Exit Delay 2: seconds

Entry Delay 2: seconds

* As an example, the designated main Entry/Exit may be a front door, and the designated alternate Entry/Exit could be a back door or a door leading from a garage into the building.

SECURITY CODES

General

At the time of installation, your installer programmed a personal four-digit* "master" code, known only to you and yours. This code is used to perform most system functions, including arming and disarming of the system.

* As a high-security feature, the system can be programmed to require a 6-digit code for arming and disarming. The 6-digit code consists of the 2-digit user number plus a 4-digit code. Ask your installer if this feature has been programmed.

User Codes

As an additional safety feature, temporary user codes can be assigned for use by those not having a need to know the master code. Temporary codes are assigned "user numbers," to identify the users of each code. See your installer for the number of temporary user numbers available with your system. Note that the master code remains in effect even though other user codes are assigned.

User 22 Special Feature (Babysitter Code option): The system can be programmed so that user 22 can disarm the system *only* if the system was previously armed by user 22. Ask your installer if this option is programmed for your system.

Duress Code

This feature is intended for use when you are forced to disarm or arm the system under threat. When used, the system will act normally, but can silently notify the central station of your situation, if that service has been provided. The duress code is the same as your user code, except that the last digit is increased by one. For example, if the normal security code is "1 2 3 4", the duress code is "1 2 3 5". User codes that end in "9" (e.g., 6349) cannot activate a duress alarm (i.e., 6350 is not a duress alarm).

Important: *This code is useful only when connected to a central alarm monitoring station.*

SECURITY CODES

Quick Arming

If your system supports "Quick Arming", the [#] key can be pressed in place of the security code when arming the system (check with your installer). The security code is *always* required when disarming the system, however.

To Assign or Delete User Codes

It is recommended that obvious codes such as 1111 or 1234 not be assigned.

Up to 68 temporary User codes (03-70) can be assigned by User 2 (the Master User).

Whoever is assigned as User 3 can also assign temporary user codes, but only for Users 04 through 69. Note that User 3's code is that person's Master code for all user code assignments and deletions outlined below.

Procedure:

1. Enter your Master code and press the **CODE** key.
2. Enter User Number to be assigned or deleted (03-70 or 04-69, see above).
3. If assigning a user code, enter the temporary code for that User Number.

The console will emit a single tone if completed successfully.

If deleting a user's code, perform steps 1 & 2 and re-enter the Master code. The console will then emit a single tone, indicating that the User code has been deleted.

Important:

- Instruct other users to enter their codes carefully to avoid accidentally entering the Duress code, or, if desired, assign other users a code ending in "9" to prevent accidental duress code entry.
- Temporary Users should not be shown how to use any system function they do not need to know (example, bypassing protection points).
- Be sure user codes do not conflict with any Duress code.

CHECKING FOR OPEN ZONES

Using the *** READY Key**

Before arming your system, all protected doors, windows and other protection zones must be closed or bypassed (see BYPASSING section), otherwise the console will display a "Not Ready" message as shown below (also, the READY indicator present on many consoles will not be lit).

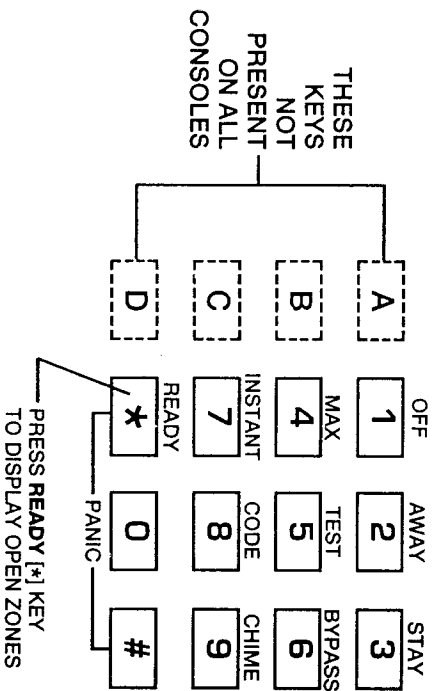

Press the **READY *** key (do not enter code first). The console will display all protection zones that are faulted, making it easier for you to secure any open zones. The "Ready" message will be displayed when all protection zones have been either closed or bypassed (also, the READY indicator present on many consoles will light).

TYPICAL ALPHA CONSOLE DISPLAY WHEN SYSTEM IS "NOT READY"

**DISARMED - PRESS *
TO SHOW FAULTS**

TYPICAL FIXED-WORD CONSOLE DISPLAY WHEN SYSTEM IS "NOT READY" →

AC
NOT READY

TYPICAL DISPLAYS AFTER PRESSING THE [*] KEY

FIXED-WORD CONSOLE

05
AC
NOT READY

ALPHA CONSOLE

FAULT 05 FRONT
UPSTAIRS BEDROOM

TYPICAL "READY" MESSAGES

AC
READY

****DISARMED****
READY TO ARM

Consoles with a READY indicator light:
If a console is equipped with a READY indicator light, the system is "ready to be armed" (all protection zones intact) when the READY indicator is lit; when not lit, the system has a faulted zone and is not ready for arming.

NOTE: All or part of the "Disarmed" message above may be replaced by a customized message programmed by the installer. Bear this in mind whenever the instructions for the Alpha Console state that the "DISARMED" message will be displayed.

BYPASSING PROTECTION ZONES

Using the 6 BYPASS Key

Single-digit zone numbers must be preceded by a zero (example, enter 01 for zone 1).

Limitations:
The system will not allow fire or emergency zones to be bypassed.

Arming the system before bypassed zones are displayed eliminates all bypasses.

All bypasses are removed when an OFF sequence (security code plus OFF) is performed. Bypasses are also removed if the arming procedure that follows the bypass procedure is not successful.

This key is used when you want to arm your system with one or more zones intentionally left unprotected. The system must be disarmed first.

1. Enter your **security code** and press the **BYPASS** key.
2. Enter zone number(s) for the zones to be bypassed (e.g. 01, 02, etc.).
3. When finished, the console will display the word **BYPASS** and along with each bypassed zone number. Wait for these zones to be displayed before arming.
4. Arm the system as usual. Bypassed zones are unprotected and will not cause an alarm when violated while your system is armed.

Quick Bypass Feature:

Your system may allow you to easily bypass all open (faulted) zones without having to enter zone numbers individually (ask your installer if this feature is active in your system). This feature is useful if, for example, you routinely leave certain windows open when arming at night. To use Quick Bypass, enter your **security code**, press the **BYPASS** key, then press the [#] key. In a few moments, all open zones will be displayed, along with the word **BYPASS**. When all bypassed zones have been displayed, arm the system as usual.

Displaying Bypassed Protection Zones:

1. Enter your **security code** and press the **BYPASS** key.
2. Wait for all bypassed protection zones to be sequentially displayed.
3. Bypassed zones can be displayed whether the system is armed or disarmed.

TYPICAL ALPHA CONSOLE DISPLAY
AFTER "BYPASS" PROCEDURE

DISARMED BYPASS
READY TO ARM

ENTER
SECURITY
CODE AND
PRESS
BYPASS
KEY

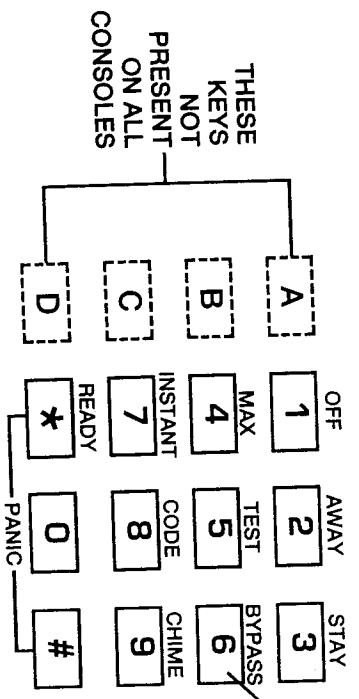

TYPICAL MESSAGES WHEN BYPASSED PROTECTION ZONES ARE DISPLAYED

ALPHA DISPLAY

BYPASS 07 FRONT
UPSTAIRS BEDROOM

EQUIVALENT FIXED-WORD
DISPLAY

AC
BYPASS
READY

FIXED-WORD DISPLAY

07
AC
BYPASS
READY

ARMING PERIMETER ONLY _____ **WITH ENTRY DELAY ON**

Using the **3 STAY Key**

Use this key when you are staying on the premises, but might expect someone to use an entry/exit door later.

1. Enter your **security code** and press the **STAY** key.
2. The console will emit three tones and display the armed message shown at the right.
3. The system is now armed. You may move freely throughout the premises, but if a protected perimeter door or window is opened, an alarm sounds.
Late arrivals can enter through an entry/exit door without causing an alarm, but they must disarm the system within the entry delay period.

Close all protected perimeter windows and doors before arming. Your system will not arm if any protection zone is open (see **CHECKING FOR OPEN ZONES** on a previous page).

ARMING PERIMETER ONLY

WITH ENTRY DELAY ON

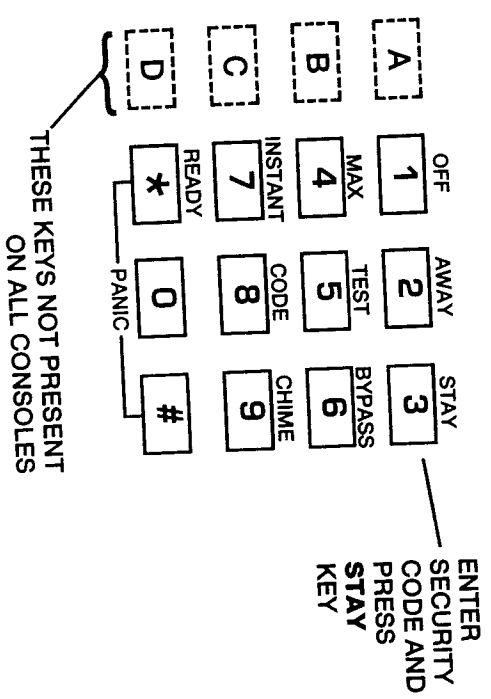

DISPLAY ON AN ALPHA CONSOLE WHEN THE SYSTEM HAS BEEN "ARMED STAY"

ARMED *STAY***
ZONE BYPASSED**

NOTE: "ZONE BYPASSED" IN THE ABOVE DISPLAY SIMPLY INDICATES THAT THE INTERIOR ZONES OF PROTECTION HAVE NOT BEEN ARMED.

EQUIVALENT FIXED-WORD CONSOLE DISPLAY WHEN THE SYSTEM HAS BEEN "ARMED STAY"

STAY
AC

ARMING PERIMETER ONLY _____ **WITH ENTRY DELAY OFF**

Using the **7 INSTANT Key**

Use this key when you are staying within the premises and do not expect anyone to use an entry/exit door.

1. Enter your **security code** and press the **INSTANT** key.
2. The console will emit three tones and display the armed message.
3. The system is now armed. You may move freely throughout the premises, but if a protected perimeter door or window is opened, an alarm sounds. The alarm also sounds immediately if anyone opens an entry/exit door.

Close all protected perimeter windows and doors before arming. Your system will not arm if any protection zone is open (see CHECKING FOR OPEN ZONES on a previous page).

ARMING PERIMETER ONLY

WITH ENTRY DELAY OFF

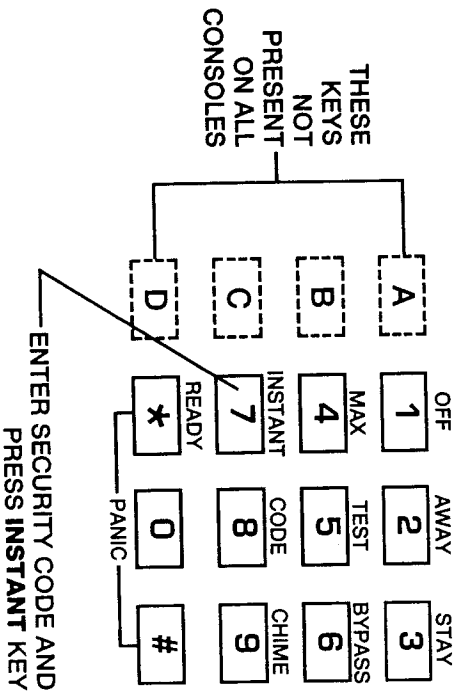

DISPLAY ON AN ALPHA CONSOLE WHEN THE SYSTEM HAS BEEN "ARMED INSTANT"

**ARMED *INSTANT*
ZONE BYPASSED**

NOTE: "ZONE BYPASSED" IN THE ABOVE DISPLAY SIMPLY INDICATES THAT THE INTERIOR ZONES OF PROTECTION HAVE NOT BEEN ARMED.

EQUIVALENT FIXED-WORD CONSOLE DISPLAY WHEN THE SYSTEM HAS BEEN "ARMED INSTANT"

**STAY
INSTANT** AC

ARMING ALL PROTECTION

WITH ENTRY DELAY ON

Using the

2 AWAY Key

1. Use this key when no one will be staying on the premises.
1. Enter your **security code** and press the **AWAY** key.
2. The console will emit two tones and display the armed message.
3. The system is now armed. If a protected door or window is opened, or if movement is detected inside the premises by motion detectors used in your system, an alarm sounds.

You may leave through a designated entry/exit door during the exit delay period without causing an alarm. You may also re-enter through an designated entry/exit door, but must disarm the system within the entry delay period.

All protected windows and doors should be closed so that the "Ready" message is displayed. Your system will not arm if any protection zone is open (see CHECKING FOR OPEN ZONES previously).

ARMING ALL PROTECTION

WITH ENTRY DELAY ON

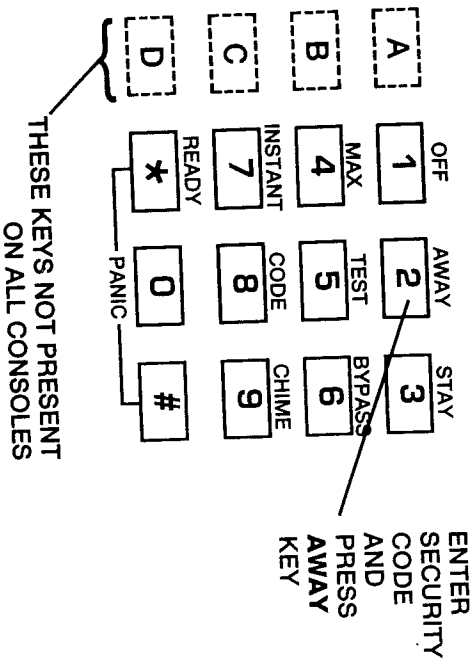

DISPLAY ON AN ALPHA CONSOLE WHEN THE SYSTEM HAS BEEN "ARMED AWAY"

ARMED ***ARMY***
YOU MAY EXIT NOW

EQUIVALENT FIXED-WORD CONSOLE DISPLAY WHEN THE SYSTEM HAS BEEN "ARMED AWAY"

AWAY
AC

ARMING ALL PROTECTION

WITH ENTRY DELAY OFF

Using the 4 MAX (MAXIMUM) Key

Use this key when the premises will be vacant for extended periods of time such as vacations, etc., or when retiring for the night and no one will be moving through protected interior areas.

1. Enter your **security code** and press the **MAX (MAXIMUM)** key.
2. The console will emit two tones and will display the armed message.
3. The system is now armed. If a protected door or window is opened, or if movement is detected inside the premises by motion detectors used in your system, an alarm sounds.
You may leave through a designated entry/exit door during the exit delay period without causing an alarm, but an alarm sounds as soon as someone re-enters.

All protected windows and doors should be closed so that the "Ready" message is displayed. Your system will not arm if any protection zone is open (see CHECKING FOR OPEN ZONES previously).

ARMING ALL PROTECTION

WITH ENTRY DELAY OFF

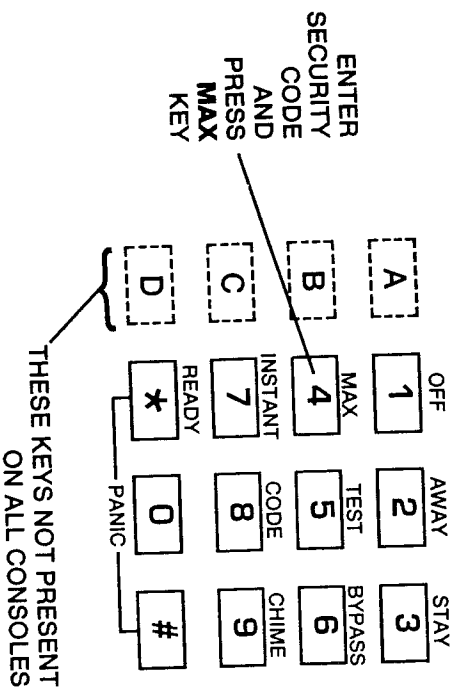

DISPLAY ON AN ALPHA CONSOLE WHEN THE SYSTEM HAS BEEN "ARMED MAXIMUM"

ARMED * MAXIMUM *
YOU MAY EXIT NOW

EQUIVALENT FIXED-WORD CONSOLE DISPLAY WHEN THE SYSTEM HAS BEEN "ARMED MAXIMUM"

AWAY AC
INSTANT

DISARMINING THE SYSTEM AND SILENCING ALARMS

Using the
1 OFF Key

The **OFF** key is used to disarm the system and to silence alarm and trouble sounds.

To Disarm the System

Enter your **security code** and press the **OFF** key. The "Ready" message will be displayed, and the console will emit a single tone to confirm that the system is disarmed.

To Silence a Burglary Alarm In Progress*

Enter your **security code** and press the **OFF** key to silence the alarm (or warning tones of a Memory of Alarm).

Note the zone in alarm on the console display, and make that zone intact (close protected door, window, etc.). Now enter another **OFF** sequence to clear the display. If the display will not clear and does not provide a "Ready" message after the displayed zone has been made intact, notify the alarm agency.

* See page 41 for additional information relevant to silencing fire alarms.

See important note at left regarding alarms that occur when returning from outside, including the Memory of Alarm feature.

Refer to the *SUMMARY OF AUDIBLE SOUNDS AND DISPLAYS* section for information which will help you to distinguish between **FIRE** and **BURGLARY** alarm sounds.

IMPORTANT:
If you return and the burglary alarm is sounding, **DO NOT ENTER THE PREMISES**, but call the police from a nearby safe location.
If you return after an alarm has occurred and the main sounder has shut itself off, the console will emit rapid tones upon entering, indicating that an alarm has occurred during your absence (this is the Memory of Alarm feature). **LEAVE AT ONCE and CONTACT THE POLICE** from a nearby safe location. When safe to do so, re-enter and follow the procedure for silencing an alarm in progress.

CHIME MODE

9 CHIME Key

Using the

Your system can be set to alert you to the opening of a protected door or window while it is disarmed by using CHIME mode. When Chime is on, three tones will sound at the Console whenever a protected door or window is opened. Pressing the **READY [*]** key will display the open protection points. This feature can be used only when the burglary system is disarmed.

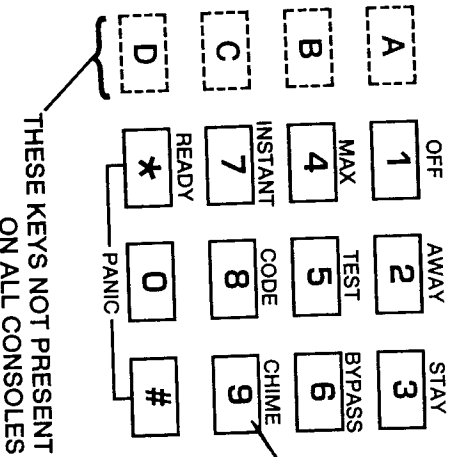

THESE KEYS NOT PRESENT ON ALL CONSOLES

To turn Chime Mode on: Enter the **security code** and press the **CHIME** key. On Alpha consoles, the CHIME message will appear for a few seconds, then go off; to check if CHIME mode is on at any time, simply press CHIME key and hold for 5 seconds.

To turn Chime Mode off: Enter the **security code** and press the **CHIME** key again. The CHIME message will disappear. On Alpha consoles, CHIME MODE OFF will appear for a few seconds, then go off.

ALPHA CONSOLE DISPLAY - CHIME TURNED ON

CHIME MODE ON

EQUIVALENT FIXED-WORD CONSOLE DISPLAY

AC
READY
CHIME

DURESS CODE

(WHEN FORCED TO DISARM/ARM UNDER THREAT)

Using the Duress Code

Enter the first three (or 5*) digits of the security code. Increase the final digit by one and then press **OFF** (or **AWAY**, etc. if arming the system). The system will disarm (or arm), but can silently notify the central station of your situation, if that service has been provided.

* If a 6-digit security code is used in your system.

Example:

Normal security code is "1 2 3 4".

Duress security code is "1 2 3 5".

Important

- This code is useful only when connected to a central station.
- Duress code capability is not present for codes ending in 9.
- Users of temporary codes must be instructed to enter their codes carefully to avoid the possibility of accidentally entering the Duress code.

PANIC (EMERGENCY) KEYS

Using Panic Keys

Your system may have been programmed to use special keys or key combinations to manually activate panic functions. The functions that might be programmed are Silent Emergency, Audible Emergency, Personal Emergency, and Fire. Your installer should have noted below which functions are active in your system. If not indicated, check with your installer.

Active Panic Functions

| Keys | Function |
|---------|----------|
| 1 and * | |
| * and # | |
| 3 and # | |
| A * | |
| B * | |
| C * | |
| D * | NOT USED |

* Keys A, B, C, and D not present on all consoles.

Note:

1 & * or A displayed as zone 95. †

* & # or B displayed as zone 99. †

3 & # or C displayed as zone 96. †

† No display occurs for silent emergency.

To use a Panic function, press both keys of the assigned pair at the same time (or key A, B, or C, if present) and hold down for at least two seconds.

A silent emergency, sends a silent alarm signal to the central station, but there will be no audible alarms or visual displays.

An audible emergency, sounds a loud, steady alarm at your console **and** at any external sounders that may be connected, and also sends a silent alarm signal to the central station (if connected). **ALARM** plus a zone number would also be displayed.

A personal emergency alarm sends an emergency message to the central station (if connected) and will sound at consoles, but not at external bells or sirens (**ALARM** plus a zone number would also be displayed).

A fire alarm sends a fire alarm message to the central station and will uniquely sound external bells and sirens (**FIRE** plus a zone number would also be displayed).

USING THE KEYSWITCH

General

Your system may be equipped with a keyswitch for use when arming and disarming. A red and green light on the keyswitch plate indicates the status of your system as follows:

Green Light: Lights when the system is **disarmed and ready** to be armed (no open protection zones). If the system is disarmed and the Green light is off, it indicates that the system is not ready (one or more protection zones are open).

Red Light: Lights when the system is armed or memory of alarm exists, as follows:

LIT STEADILY: System is **armed in AWAY** mode.

SLOW FLASHING: System is **armed in STAY** mode.

RAPID FLASHING: **Memory of alarm.** An alarm has occurred.

Arming

To arm in the AWAY mode, turn key to right for 1/2 second and release. Consoles will emit two tones and the Red light will stay on steadily.

To arm in the STAY mode, turn key to right position for longer than one second, then release. Consoles will emit three tones and the Red light will flash slowly.

Disarming

To disarm the system, turn the key to the right and release.

If an alarm has occurred during the armed time, the Red light will be flashing rapidly to indicate memory of alarm.

GREEN LIGHT
ON = DISARMED, READY
OFF* = DISARMED, NOT READY
* GREEN LIGHT IS ALSO OFF WHEN THE
SYSTEM IS IN ANY OF THE "ARMED"
MODES.

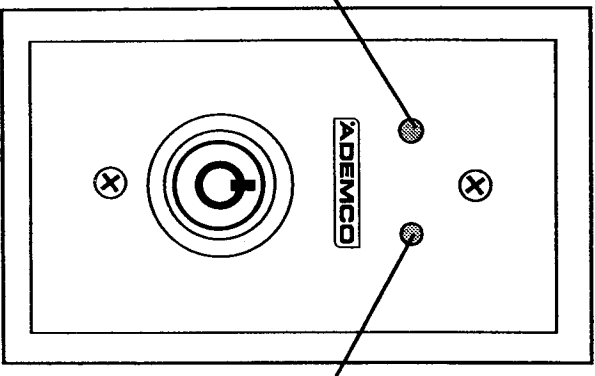

RED LIGHT
STEADY = ARMED AWAY
SLOW FLASH = ARMED STAY
RAPID FLASH = MEMORY OF ALARM

VIEWING CENTRAL STATION MESSAGES

Alpha Consoles Only

Using this Feature

You may periodically receive messages on the console display screen from your alarm monitoring agency. When a message has been sent and is waiting to be viewed, the following will appear.

**MESSAGE PRESS 0
FOR 5 SECS**

When the "0" key is pressed and held for 5 seconds, the message transmitted to you will appear on your display screen. The message could take up to four screens to display all the information available.

SELF-HELP FEATURE

Alpha Consoles Only

Using this Feature

Abbreviated User's instructions can be displayed on an ALPHA console's display screen. To view these instructions, press and hold down the function key of interest (OFF, AWAY, STAY, MAX, TEST, BYPASS, INSTANT, CODE, CHIME, READY, [*], or [#]) until the description begins to appear (about 5 seconds), then release it. The console will display two lines of text at a time.

This self-help feature is useful if this Manual is not accessible when you need to perform a seldom-used system procedure with which you are not familiar, and may be used when the system is in the armed or the disarmed state.

REVIEWING ALL ZONE DESCRIPTIONS

Alpha Consoles Only

General

Your installer may have programmed descriptive words to identify the location of each of the protection zones in your system. For example, zone 01 may have been given the description "FRONT DOOR", zone 02 the description "MASTER BEDROOM", etc.

To review all the protection zones in your system and the descriptions that have been assigned to them, do the following:

1. The system must be in the disarmed state and "ready to arm" (i.e., all zones intact). Descriptions for all zones will not be displayed if any are faulted.
2. Press and hold down the READY [*] key for at least 5 seconds. The abbreviated instructions for the READY key will appear first, followed by the descriptions that have been programmed for the zones in your system.

TESTING THE SYSTEM

TO BE CONDUCTED WEEKLY

Testing Your System

Note that no alarm reports will be sent to the central monitoring station while the system is in the Test mode.

The Console will sound a single tone at 15-second intervals (if no protection points are violated), as a reminder that the system is in the Test mode.

The Test key puts your system into the Test mode, which allows each protection point to be checked for proper operation.

1. With the system in the disarmed mode, close all protected windows, doors, etc. The "Ready to Arm" message should be displayed.
2. Enter your **security code** and press the **TEST** key.

3. The external sounder should sound for 3 seconds and then turn off.

If the sounder fails to sound, the system's back-up battery may be too weak to activate the external sounder (Fixed-word consoles will display **BAT with no ID number**, Alpha consoles will display **SYSTEM LO BAT**). This may be due to a weak back-up battery caused by activation of the external siren or bell for an extended period during a recent alarm.

4. Even if the sounder fails to sound, the system will still enter the Test mode, allowing each protection point to be checked for proper operation, as indicated in steps 5 through 10.

Note: If a message indicating a low system back-up battery was displayed, allow at least 8 hours for the battery to re-charge, then enter the Test mode again to check that the sounder comes on for 3 seconds and then turns off. If it does not, the sounder may be at fault and you should call for service.

5. **Doors and Windows:** Open and close each protected door and window in turn. Each action should produce 3 tones. The identification of each faulted protection point should also be displayed.

TESTING THE SYSTEM

6. **Motion Detectors:** Walk in front of any interior motion detectors (if used) and listen for 3 tones as movement is detected. The identification of the detector should also be displayed when the motion detector is activated.
7. **Smoke Detectors:** Follow the manufacturer's instructions to test all smoke detectors to ensure that all are functioning properly. The identification of each detector should also be displayed when each is activated.
8. **Personal Emergency Wireless Transmitter** (if used in your system): Take your personal emergency transmitter(s) where you are most likely to use it.
 - A. When testing the emergency transmitter, you should be no farther than 150 feet from the control cabinet, whether you are indoors or outdoors.
 - B. **Press and hold the large button on the transmitter** for at least 2 seconds. The console will emit 3 tones and display the number **62** or **63**.
 - C. Release the button on the transmitter. The Control will produce 3 tones and the display will turn off.
If no tones are heard after the emergency transmitter's test button has been pressed, the transmitter may be inoperative or the particular location where it is being tested may have a poor signal path to the control. Try other locations in the same general area.
9. When all protection points have been checked, there should be no zone identification numbers displayed. If a problem is experienced with any protection point (no confirming sounds, no display), **CALL FOR SERVICE**.
10. **Turn off Test mode** by entering the security code and pressing the **OFF** key.

TROUBLE CONDITIONS

ALPHA CONSOLES

Typical "Check" Displays

Not all systems use wireless transmitters and receivers.

*** NOTE:**
Your installer may have selected other descriptive words to be displayed for this condition. Check with the installer to be sure.

† NOTE:
Not all systems use wired zone expansion units.

Other Trouble Conditions

If "CHECK" appears on the console's display, accompanied by rapid tones at the console, it indicates a trouble condition in the system. The audible warning tones may be silenced by pressing any key.

1. A display of CHECK, accompanied by a display of CALL FOR SERVICE or by a display of "97": This indicates that a problem exists in the system that eliminates some of the protection. CALL FOR SERVICE IMMEDIATELY.
2. A display of CHECK, accompanied by a display of one or more zone descriptors (displayed sequentially): This indicates that a problem exists with those zones being displayed. First, determine if the zone(s) displayed are intact and make them so if they are not. If the problem has been corrected, the display of the zone descriptor(s) and CHECK should clear. If not, key an OFF sequence (Code plus OFF). If the display persists, CALL FOR SERVICE IMMEDIATELY.
3. A display of CHECK, accompanied by a display of one of the following:
ZONE 88, ZONE 89, 90 RADIO SUPERVISION*, 91 RADIO SUPERVISION*.
This indicates a problem with a wireless receiver in your system, resulting in the elimination of some protection. CALL FOR SERVICE IMMEDIATELY.
4. A display of CHECK, with a numeric display of 81 through 84 indicates a problem with a wired zone expansion unit in your system, resulting in the loss of some protection. CALL FOR SERVICE IMMEDIATELY.
1. A display of MODEM COMM: This indicates that the system is in communication with the alarm monitoring station. If this display remains on for more than 10 minutes, call your service company.

TROUBLE CONDITIONS

ALPHA CONSOLES

2. **A display of COMM FAILURE:** A failure has occurred in the telephone communication portion of your system, and is not able to send messages to your alarm monitoring station. **CALL FOR SERVICE IMMEDIATELY.**
3. **A display of LO BAT and one or more zone numbers and descriptors, accompanied by a "tone" every 60 seconds at the console:** A low battery condition exists in a wireless sensor/transmitter. We recommend that the battery be replaced as soon as possible. The warning tones can be silenced by keying an OFF sequence (Code plus OFF). After the new battery has been installed, the low battery message display should clear within approximately 1 hour.
4. **A display of SYSTEM LO BAT with no zone numbers:** This indicates that the system back-up battery has a low battery condition. If there is no apparent cause for this (such as AC power having been cut off for an extended period, or an alarm having caused the external sounder to be activated for a long period), **CALL FOR SERVICE.**

Power Failure

On some consoles, a **POWER** indicator, when off, indicates that AC power to the system is off and it is operating on the back-up battery. On other consoles, the message "**AC POWER LOSS**" (cycled on and off approximately every 30 seconds with other messages that are present) will be displayed when AC power fails and the system is operating on battery power only.

If only some lights are out on the premises, check circuit breakers and fuses and reset or replace as necessary. **CALL FOR SERVICE** if AC power cannot be restored.

TROUBLE CONDITIONS

FIXED-WORD CONSOLES

Typical "CHECK" Displays

If **CHECK** appears on the console's display, accompanied by rapid tones at the console, it indicates a trouble condition in the system. The audible warning sounds may be silenced by pressing any key.

1. A display of the word **CHECK**, accompanied by a numeric display of one or more zone numbers (displayed sequentially): This indicates that a problem exists with those protection zones being displayed. If zone numbers **88** through **91** are displayed, refer to the next item (2) below.

Not all systems use wireless transmitters and receivers

† NOTE:

Not all systems use wired zone expansion units.

2. A display of the word **CHECK**, accompanied by a numeric display of **88** through **91**: This indicates that a problem exists with a wireless receiver used in your system. Since this will result in the elimination of some of your protection, **CALL FOR SERVICE IMMEDIATELY**.
3. A display of **CHECK**, with a numeric display of **81** through **84** indicates a problem with a wired zone expansion unit† in your system, resulting in the loss of some protection. **CALL FOR SERVICE IMMEDIATELY**.
1. A display of the word **CHECK** accompanied by a display of "97". This indicates that a problem exists in the system that eliminates some of the protection. **CALL FOR SERVICE IMMEDIATELY**.

Other Trouble Conditions

FIXED-WORD CONSOLES

TROUBLE CONDITIONS

2. *A display of CC in the numeric display area:* Indicates that the system is communicating with the alarm monitoring station. If displayed for more than 10 minutes, call your service company.
3. *A display of FC in the numeric display area:* This indicates that a failure has occurred in the telephone communication portion of your system, which means that your system is not able to send messages to your alarm monitoring station. **CALL FOR SERVICE IMMEDIATELY.**
4. *A display of BAT and one or more zone numbers accompanied by a tone every 60 seconds at the console:* This indicates that a low battery condition exists in a wireless sensor/transmitter. We recommend that the battery be replaced as soon as possible. The warning tones can be silenced by keying an OFF sequence (Code plus OFF); after the new battery has been installed, the low battery message display should clear within approximately 1 hour.

A display of BAT with no zone numbers: This indicates that the system back-up battery has a low battery condition. If there is no apparent cause for this (such as AC power having been cut off for an extended period, or an alarm having caused the external sounder to be activated for a long period), **CALL FOR SERVICE IMMEDIATELY.**

Power Failure

On all fixed-word consoles, if AC power to the system is cut off, the message "NOAC" is displayed, and the Console is operating on battery power only. On consoles with a **POWER** indicator, if AC power to the system is off, this indicator will be off.

If only some lights are out on the premises, check circuit breakers and fuses and reset or replace as necessary. **CALL FOR SERVICE** if AC power cannot be restored.

FIRE ALARM SYSTEM

IF INSTALLED

TYPICAL FIRE EMERGENCY DISPLAYS

FIXED-WORD DISPLAY

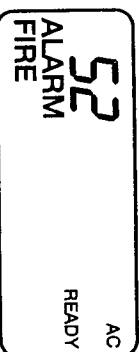

ALPHA DISPLAY



Silencing Fire Alarms

1. Silence the alarm by entering your **security code** and pressing the **OFF** key. To clear the display, enter your code and press the **OFF** key again (clears Memory of Alarm).
2. If the Console does not indicate a "READY" condition after the second OFF sequence, press the **READY** key to display the zone(s) that are faulted. Be sure to check that smoke detectors are not responding to smoke or heat-producing objects in their vicinity. Should this be the case, eliminate the source of heat or smoke.
3. If this does not remedy the problem, there may still be smoke in the detector. Clear it by fanning the detector for about 30 seconds.
4. When the problem has been corrected, clear the display by entering your code and pressing the **OFF** key.

NATIONAL FIRE PROTECTION ASSOCIATION RECOMMENDATIONS ON SMOKE DETECTORS

General

With regard to the number and placement of smoke/heat detectors, we subscribe to the recommendations contained in the National Fire Protection Association's Standard #74 noted below.

Early warning fire detection is best achieved by the installation of fire detection equipment in all rooms and areas of the household as follows: A smoke detector installed outside of each separate sleeping area, in the immediate vicinity of the bedrooms and on each additional story of the family living unit, including basements and excluding crawl spaces and unfinished attics.

In addition, it is recommended that the householder consider the use of heat or smoke detectors in the living room, dining room, bedroom(s), kitchen, hallway(s), attic, furnace room, utility and storage rooms, basements and attached garages.

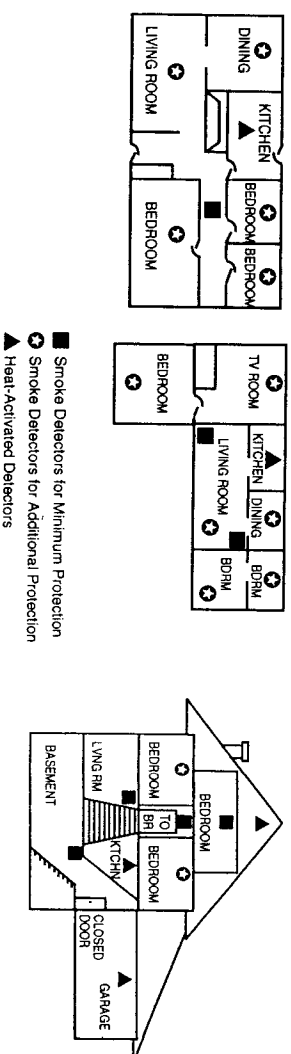

EMERGENCY EVACUATION

Steps to Safety

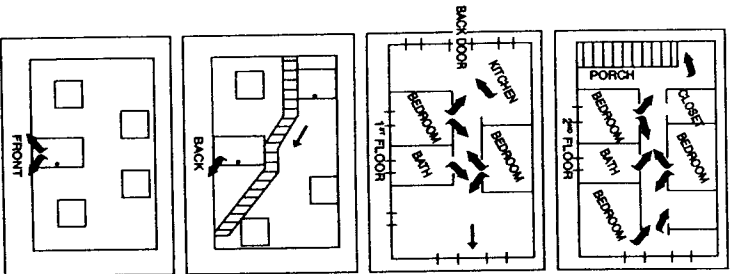

Establish and regularly practice a plan of escape in the event of fire. The following steps are recommended by the National Fire Protection Association:

1. Plan on your detector or your interior and/or exterior sounders warning all occupants.
2. Determine two means of escape from each room. One path of escape should lead to the door that permits normal exit from the building. The other may be a window, should your path be unpassable. Station an escape ladder at such windows if there is a long drop to the ground.
3. Sketch a floor plan of the building. Show windows, doors, stairs and rooftops that can be used to escape. Indicate escape routes for each room. Keep these routes free from obstruction and post copies of the escape routes in every room.
4. Assure that all bedroom doors are shut while you are asleep. This will prevent deadly smoke from entering while you escape.
5. Try the door. If the door is hot, check your alternate escape route. If the door is cool, open it cautiously. Be prepared to slam the door if smoke or heat rushes in.
6. Keep close to the floor – smoke and hot gases rise. Breathe through a cloth (wet, if possible) and take short, shallow breaths.
7. Escape quickly; don't panic.
8. Establish a common meeting place outdoors, away from your house, where everyone can meet and then take steps to contact the authorities and account for those missing. Choose someone to assure that nobody returns to the house — many die going back.

SUMMARY OF AUDIBLE SOUNDS & DISPLAYS - ALPHA CONSOLES

| SOUND | CAUSE | DISPLAY |
|--|--|---|
| LOUD, INTERRUPTED* (Console & External) | FIRE ALARM | FIRE and description of zone in alarm is displayed. |
| LOUD, CONTINUOUS* (Console & External) | BURGLARY/AUDIBLE EMERGENCY ALARM | ALARM and description of zone in alarm is displayed. |
| ONE SHORT TONE (not repeated) | a. SYSTEM DISARM b. SYSTEM ARMING ATTEMPT WITH AN OPEN ZONE c. BYPASS VERIFY | a. DISARMED/READY TO ARM is displayed. b. The number and description of open protection zone is displayed. c. Numbers and descriptions of the bypassed protection zones are displayed (one tone is heard for each zone displayed). Then, the following is displayed: DISARMED BYPASS/Ready to Arm |
| ONE SHORT TONE (every 15 seconds) | SYSTEM IS IN TEST MODE | Opened zone identifications will be displayed. |
| ONE SHORT TONE (every 60 seconds) | LOW BATTERY IN A TRANSMITTER | LO BAT plus number and description for transmitter is displayed. |
| TWO SHORT TONES | ARM AWAY OR MAXIMUM | ARMED AWAY or ARMED MAXIMUM is displayed. Red ARMED indicator is lit. |
| THREE SHORT TONES | a. ARM STAY OR INSTANT b. ZONE OPENED WHILE SYSTEM IS IN CHIME MODE c. ENTRY WARNING** | a. ARMED STAY/ZONE BYPASSED or ARMED INSTANT/ZONE BYPASSED displayed. Red ARMED indicator lit. b. CHIME MODE ON displayed. Description of open zone will be displayed if the [*] key is pressed. c. DISARM SYSTEM OR ALARM WILL OCCUR is displayed. |
| RAPID TONES | a. TROUBLE b. AC POWER LOSS ALERT c. MEMORY OF ALARM | a. CHECK displayed, plus description of troubled zone. b. AC LOSS displayed (alternated with other displays, if present). c. FIRE or ALARM displayed, plus description of zone in alarm. |
| SLOW TONES | a. ENTRY DELAY WARNING** b. EXIT DELAY WARNING (if programmed) | a. DISARM SYSTEM OR ALARM WILL OCCUR displayed. Exceeding the delay time without disarming causes alarm. b. ARMED AWAY or ARMED MAXIMUM is displayed. plus You may exit now. |

* If bell is used as external sounder, fire alarm is pulsed ring, burglary/audible emergency is steady ring.

** Entry warning may consist of three short tones or slow continuous series of tones, as programmed by your installer.

SUMMARY OF AUDIBLE SOUNDS & DISPLAYS - FIXED-WORD CONSOLES

| SOUND | CAUSE | DISPLAY |
|---|---|---|
| LOUD, INTERRUPTED* (Console & External) | FIRE ALARM | FIRE and ALARM is displayed; protection zone in alarm is also displayed. |
| LOUD, CONTINUOUS* (Console & External) | BURGLARY/AUDIBLE EMERGENCY ALARM | ALARM is displayed; protection zone in alarm is also displayed. |
| ONE SHORT TONE (not repeated) | <ul style="list-style-type: none"> a. SYSTEM DISARM b. SYSTEM ARMING ATTEMPT WITH AN OPEN ZONE. c. BYPASS VERIFY | <ul style="list-style-type: none"> a. Only READY is displayed. b. NOT READY is displayed, open protection zone number is also displayed. c. The bypassed protection zone numbers are displayed (one tone for each number displayed). BYPASS also displayed. |
| ONE SHORT TONE (once every 60 secs.) | SYSTEM IS IN TEST MODE | Opened zone identifications will appear. |
| ONE TONE every 60 seconds | LOW BATTERY IN A TRANSMITTER | BAT displayed with ID number of transmitter. |
| TWO SHORT TONES | ARM AWAY OR MAXIMUM | AWAY and possibly INSTANT are displayed. |
| THREE SHORT TONES | <ul style="list-style-type: none"> a. ARM STAY OR INSTANT b. ZONE OPENED WITH SYSTEM IN CHIME MODE. c. ENTRY WARNING** | <ul style="list-style-type: none"> a. STAY and possibly INSTANT are displayed b. CHIME displayed, open protection zone number is displayed. c. No display. |
| RAPID TONES | <ul style="list-style-type: none"> a. TROUBLE b. AC POWER LOSS ALERT c. MEMORY OF ALARM | <ul style="list-style-type: none"> a. CHECK displayed. Troubled protection zone is displayed. b. NO AC displayed (alternated with other displays, if present). c. FIRE and/or ALARM is displayed; zone in alarm is displayed. |
| SLOW TONES | <ul style="list-style-type: none"> a. ENTRY DELAY WARNING** b. EXIT DELAY WARNING (if programmed) | <ul style="list-style-type: none"> a. None during delay; exceeding the delay time without disarming causes alarm. b. Normal armed AWAY, or AWAY/INSTANT (MAXIMUM) display. |

* If bell is used as external sounder, fire alarm is pulsed ring; burglary/audible emergency is steady ring.

** Entry warning may consist of three short tones or slow continuous series of tones, as programmed by your installer.

PROTECTION ZONES

General Information

One or more sensing devices will have been assigned by the installer to each of the various protection zones in your system (although not every zone may have been used). For example, the sensing device on your Entry/Exit door may have been assigned to zone 01, sensing devices on windows in the master bedroom to zone 02, and so on. The following chart has been provided for your convenience. Your installer will assist you in recording the information.

ID numbers 01-64 represent sensor/detector protection points. ID numbers 95, 96 or 99 represent "Panic" alarm codes (see next page). Other ID numbers may appear when certain system problems are present (see *TROUBLE CONDITIONS* on previous pages).

PROTECTION POINT DESCRIPTIONS

| Zone | Location/Description | Zone | Location/Description |
|------|----------------------|------|----------------------|
| 01 | _____ | 12 | _____ |
| 02 | _____ | 13 | _____ |
| 03 | _____ | 14 | _____ |
| 04 | _____ | 15 | _____ |
| 05 | _____ | 16 | _____ |
| 06 | _____ | 17 | _____ |
| 07 | _____ | 18 | _____ |
| 08 | _____ | 19 | _____ |
| 09 | _____ | 21 | _____ |
| 10 | _____ | 22 | _____ |
| 11 | _____ | 23 | _____ |

| Zone | Location/Description |
|------|----------------------|
| 24 | |
| 25 | |
| 26 | |
| 27 | |
| 28 | |
| 29 | |
| 30 | |
| 31 | |
| 32 | |
| 33 | |
| 34 | |
| 35 | |
| 36 | |
| 37 | |
| 38 | |
| 39 | |
| 40 | |
| 41 | |
| 42 | |
| 43 | |
| 44 | |
| 45 | |
| 46 | |
| 47 | |
| 48 | |

| Zone | Location/Description |
|------|----------------------|
| 49 | |
| 50 | |
| 51 | |
| 52 | |
| 53 | |
| 54 | |
| 55 | |
| 56 | |
| 57 | |
| 58 | |
| 59 | |
| 60 | |
| 61 | |
| 62 | |
| 63 | |
| 64 | |

Other numeric displays may also appear on your console:

| Display | Meaning |
|---------|--|
| 95* | * May be displayed when Emergency keys are pressed |
| 96* | (see Panic section). |
| 99* | |
| 88-91 | RF Receiver Faults. † |
| 81-84 | Wired zone expander fault. † |

† Not all systems use wireless receivers or wired zone expanders.

QUICK REFERENCE OPERATING GUIDE

| For This Function | Press These Keys | Comments |
|---|---|--|
| DISPLAYING OPEN ZONES | [*] Key (with system disarmed) | Open zone(s) will be displayed |
| PERIMETER PROTECTION (with entry delay) | Security Code + STAY [3] | Interior unarmed for freedom of movement inside. Entry and exit delay in effect. |
| PERIMETER PROTECTION (with no entry delay) | Security Code + INSTANT [7] | Interior unarmed for freedom of movement inside. Exit delay is in effect. |
| FULL PROTECTION PERIMETER & INTERIOR | Security Code + AWAY [2] | Perimeter and interior protected. Exit delay is (with entry delay) in effect. |
| FULL PROTECTION PERIMETER & INTERIOR | Security Code + MAX [4] | Perimeter and interior protected. Exit delay is (with no entry delay) in effect. |
| DISARMING SYSTEM (and silencing alarms) | Security Code + OFF [1] | System is disarmed and any alarms silenced. |
| BYPASSING PROTECTION ZONES | Security Code + BYPASS [6] + Zone number (01, 02, etc.) | Zones bypassed will be unprotected. |
| INITIATING EMERGENCY ALARMS | Key A, B, or C, or Key pairs * & #, 1 & * or 3 & # (see page 29) | Press key assigned for the desired emergency alarm (silent, audible, or Fire) |
| ADDING A TEMPORARY USER CODE DELETING A TEMPORARY CODE | Master Security Code + CODE [8] + User # + Temporary Code Master Security Code + CODE [8] + User # to be deleted + Master Code | Temporary code can be used to perform system commands until that code is deleted. |
| ENTERING CHIME MODE EXITING CHIME MODE | Security Code + CHIME [9] Security Code + CHIME [9] again | Opening or closing any protected window, door, etc. will produce 3 tones when the system is in the Chime mode. |
| ENTERING TEST MODE EXITING TEST MODE | Security Code + TEST [5] Security Code + OFF [1] | External sounder (if used) will sound for 3 seconds. In Test mode, opening or closing any protected window, door, etc. will cause 3 tones. |

MAINTAINING YOUR SYSTEM

Taking Care of Your System

The components of your security system are designed to be as free of maintenance as possible. However, there are some things you can do to make sure that your system is in reliable working condition.

1. Test your system weekly.
2. Test the system after any alarm occurs (see **TESTING THE SYSTEM**).

Replacing Batteries in Wireless Sensors

Wireless sensors may not have been used in your security system

Each wireless sensor in your system has a 9-volt battery. The system detects a low battery in any wireless sensor, including smoke detectors, the optional personal emergency transmitter, and the optional portable wireless keypad. (A low battery in a portable wireless keypad is detected as soon as one of its keys is pressed, and the console will display 00.)

Alkaline batteries provide a minimum of 1 year of operation, and in most units and applications, provide 2–4 years of service. Actual battery life will depend on the environment in which the sensor is used, the number of signals that the transmitter in the sensor has had to send, and the specific type of sensor. Factors such as humidity, high or low temperatures or large swings in temperature, may all lead to the reduction of actual battery life in an installation.

If you have a low battery in a wireless sensor, a low battery message is displayed on the console. Typical low battery displays are shown below.

FIXED-WORD DISPLAY

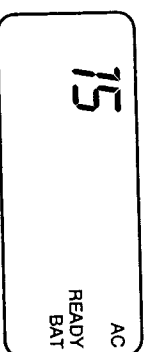

ALPHA DISPLAY



(Continued over)

MAINTAINING YOUR SYSTEM

(CONTINUED)

In addition, a battery-operated smoke detector with a low battery also emits a single "chirp" sound once approximately every 20-30 seconds, identifying itself as the smoke detector with the weak battery. If you do not replace a smoke detector's low battery, the smoke detector may sound continuously, as if there were a fire alarm.

Note: The low battery message comes on as a warning that battery replacement in indicated sensor(s) is due within 30 days. In the meantime, the sensor(s) causing the low battery indication is still fully operational.

Important: Use only batteries recommended by your installer as replacement.

The console's warning tones can be silenced by performing an OFF sequence (**security code plus OFF key**), but the Console's low battery message display will remain on as a reminder that you have a low battery condition in one or more of your sensors. When you replace the weak battery with a fresh one, the sensor will send a "good battery" signal to the control as soon as the sensor is activated (opening/closing of a protected door, window, etc.), causing the low battery display to turn off. If the sensor is not activated, the display will automatically clear within approximately 1 hour.

Silencing Low Battery Warning Tones at the Console

Routine Care

- Treat the components of your security system as you would any other electrical equipment. Do not slam sensor-protected doors or windows.
- Keep dust from accumulating on the console and all protective sensors, particularly on motion sensors and smoke detectors.
- The console and sensors should be cleaned carefully with a dry soft cloth. **Do not spray water or any other fluid on the units.**

FEDERAL COMMUNICATIONS COMMISSION (FCC) PART 15 STATEMENT

This equipment has been tested to FCC requirements and has been found acceptable for use. The FCC requires the following statement for your information:

This equipment generates and uses radio frequency energy and if not installed and used properly, that is, in strict accordance with the manufacturer's instructions, may cause interference to radio and television reception. It has been type tested and found to comply with the limits for a Class B computing device in accordance with the specifications in Part 15 of FCC Rules, which are designed to provide reasonable protection against such interference in a residential installation. However, there is no guarantee that interference will not occur in a particular installation. If this equipment does cause interference to radio or television reception, which can be determined by turning the equipment off and on, the user is encouraged to try to correct the interference by one or more of the following measures:

- If using an indoor antenna, have a quality outdoor antenna installed.
- Reorient the receiving antenna until interference is reduced or eliminated.
- Move the receiver away from the control/communicator.
- Move the antenna leads away from any wire runs to the control/communicator.
- Plug the control/communicator into a different outlet so that it and the receiver are on different branch circuits.

If necessary, the user should consult the dealer or an experienced radio/television technician for additional suggestions.

The user or installer may find the following booklet prepared by the Federal Communications Commission helpful:
"Interference Handbook"

This booklet is available from the U.S. Government Printing Office, Washington, DC 20402.

The user shall not make any changes or modifications to the equipment unless authorized by the Installation Instructions or User's Manual. Unauthorized changes or modifications could void the user's authority to operate the equipment.

UL NOTICE: This is a "Grade A" Residential System.

FEDERAL COMMUNICATIONS COMMISSION (FCC) PART 68 NOTICE

This equipment complies with Part 68 of the FCC rules. On the front cover of this equipment is a label that contains, among other information, the FCC registration number and ringer equivalence number (REN) for this equipment. If requested, this information must be provided to the telephone company.

This equipment uses the following jacks:

An RJ31X is used to connect this equipment to the telephone network.

The REN is used to determine the quantity of devices which may be connected to the telephone line. Excessive RENs on the telephone line may result in the devices not ringing in response to an incoming call. In most, but not all areas, the sum of the RENs should not exceed five (5.0). To be certain of the number of devices that may be connected to the line, as determined by the total RENs, contact the telephone company to determine the maximum REN for the calling area.

If this equipment causes harm to the telephone network, the telephone company will notify you in advance that temporary discontinuance of service may be required. If advance notice is not practical, the telephone company will notify the customer as soon as possible. Also, you will be advised of your right to file a complaint with the FCC if you believe necessary.

The telephone company may make changes in its facilities, equipment, operations, or procedures that could affect the operation of the equipment. If this happens, the telephone company will provide advance notice in order for you to make the necessary modifications in order to maintain uninterrupted service.

If trouble is experienced with this equipment, please contact the manufacturer for repair and warranty information. If the trouble is causing harm to the telephone network, the telephone company may request you remove the equipment from the network until the problem is resolved.

There are no user serviceable components in this product, and all necessary repairs must be made by the manufacturer. Other repair methods may invalidate the FCC registration on this product.

This equipment cannot be used on telephone company-provided coin service. Connection to Party Line Service is subject to state tariffs.

This equipment is hearing-aid compatible.

When programming or making test calls to an emergency number, briefly explain to the dispatcher the reason for the call. Perform such activities in the off-peak hours; such as early morning or late evening.